

BRAVE

MBRPB160HA

ITEM NUMBER: BRPB160H

SERIAL NUMBER:

Owner's Manual

Walk-Behind Blower

WARNING

READ and UNDERSTAND this manual completely before using blower.

All operators of this equipment must read and completely understand all safety information, operating instructions, maintenance and storage instructions. Failure to properly operate and maintain the blower could result in serious injury to the operator and bystanders from moving parts that can crush or cut, flying objects, burns, fire or explosion or carbon monoxide poisoning and be aware of the following hazards.

- **WARNING:** Do not operate machine without guards, shield and other safety items in place and working correctly.
- **WARNING:** Do not operate the machine within a 50' radius of people, animals, automobiles or glassed areas which might be damaged or hurt by projectiles.
- **WARNING:** Operator must wear eye protection when operating the machine.
- **WARNING:** This unit is designed specifically for leaf and debris blowing and is not intended for any other use.
- **WARNING:** If an object, person or animal enters the path of the blower and direction of where the blower is blowing debris STOP immediately and wait for object or person to leave before continuing.
- **WARNING:** Keep hands away from air intake and air outlet chute at all times.
- **DANGER:** Rotating fan – Keep Hands Away! Do not attempt to clear debris of any sort from the intake area or discharge area of the blower while the engine is running.

STOP!

ADD OIL TO ENGINE BEFORE USING: Engine is shipped without oil. **DO NOT** start blower without first adding oil. **INSPECT COMPONENTS:** Closely inspect to make sure no components are missing or damaged. See Initial Unpacking and Set-up for instructions and for whom to contact to report missing or damaged parts.

Any Questions, Comments, Problems or Parts Orders
Call Brave Product Support 1-800-350-8739

Table of Contents

	page
1) Applications and uses _____	1
2) Service information _____	2
3) Safety Information _____	2,3,4
4) Warnings (Do Not) _____	4
5) Warnings (Do) _____	4
6) Engine and Fuel Warnings _____	4
7) Blower Assembly _____	5
8) Operating Instructions _____	6
9) Maintenance _____	6
10) Exploded View _____	7,8
11) Parts List _____	9,10

1) Applications and uses:

The versatility of the Brave Blower makes it ideal for a wide range of uses.

Blowing leaves, Drying Tennis courts, Blowing grass clippings, Cleaning parking lots, cleaning driveways, preparing roof surfaces before repairs are made, blowing thatch from golf course greens and tees.

This manual provides information for safe and efficient operation and service. It is important that you read and understand this manual before operating your blower.



Warning: The engine exhaust from this product contains chemicals known to the State of California to cause cancer, birth defects or other reproductive harm.

2) Service information

Engine: Refer to the enclosed Engine Manual provided by the engine manufacturer or an authorized repair facility for replacement parts and engine warranty.

Blower Components: Contact your local Brave dealer.

3) Safety Information



WARNING

DANGER



This symbol indicates important safety instructions

**When you see this symbol,  pay special attention to its warning!!
Stay Alert!!**



WARNING

DANGER



TO REDUCE THE POTENTIAL FOR ACCIDENTS, ALWAYS COMPLY WITH THE SAFETY INSTRUCTIONS IN THIS MANUAL. FAILURE TO DO SO MAY RESULT IN PERSONAL INJURY AND / OR EQUIPMENT AND PROPERTY DAMAGE.



WARNING

DANGER



IMPROPER USE OR CARE OF THE BLOWER, FAILURE TO WEAR PROPER SAFETY PROTECTION CAN RESULT IN SERIOUS INJURY.

READ AND UNDERSTAND THE RULES FOR SAFE OPERATION AND ALL INSTRUCTIONS IN THIS MANUAL.

WEAR HEARING AND EYE PROTECTION AT ALL TIMES WHEN OPERATING THIS BLOWER



Safety Decals

An important part of the safety information for this blower are the safety decals found on various parts of the blower. These decals must always remain visible and in good condition. It is your responsibility to replace the decals if they become worn, damaged or hard to read. A sample of the decal is shown.

Caution: Thrown Objects.

Keep Bystanders away

Always wear Eye and Ear protection



IMPORTANT
Before performing any service or maintenance, disconnect the spark plug wire and make sure the throttle and kill switch is in the off position.

Read and understand the owners manual. Pay particular attention to ALL sections regarding safety. Keep your owners manual in a secure place for future reference.

Keep hands and feet away from discharge areas. Rotating fan will cause serious injury.

P/N 1100-074
Warning Label



General safety Rules

A) Read and understand the operators manual. Pay specific attention to all areas pertaining to safety. Keep your operators manual in a secure place.

B)  WARNING --- KEEP CHILDREN, PETS, and BYSTANDERS AWAY ---Do not permit children to touch blower. Keep children a safe distance away from work area. Never allow a person under the influence of alcohol or drugs to operate the blower.

C) DO NOT OVERREACH OR STAND ON UNSTABLE SURFACES when operating the blower. Keep good footing at all times.

D) WHEN OPERATING MULTIPLE MACHINES ---Keep a safe distance between operators when working simultaneously.

WARNING



DANGER



Misuse of blower or failure to follow all safety precautions may result in serious injury to the operator or others.

read and understand the following before attempting to operate this blower!!!

▲ 4) WARNINGS --- DO NOT DO!

- A) ▲ DANGER ROTATING FAN --- KEEP HANDS AWAY. DO NOT attempt to clear debris of any sort from the intake area or discharge area of the blower while the engine is running.**
- B) DO NOT POINT THE BLOWER DISCHARGE OUTLET in the direction of people, cars, glass, or other items which could be injured or damaged by flying debris.**
- C) DO NOT ATTEMPT TO REPAIR BLOWER --- repairs should be made by an authorized Brave dealer. Make sure that only Brave and recommended engine manufacturer's parts are used.**

▲ 5) WARNINGS --- DO!

- A) BE SURE BLOWER IS PROPERLY ASSEMBLED --- Never operate the blower without all guards and deflectors in place. Make sure all hardware is properly tightened and secure.**
- B) KEEP HANDS AWAY FROM AIR INTAKE AND AIR OUTLET CHUTE --- Keep both hands on handle at all times when operating the blower.**
- C) ALWAYS KEEP THE THROTTLE (if equipped) IN THE "STOP" POSITION WHEN NOT IN USE.**
- D) DRESS PROPERLY --- Do not wear loose clothing or jewelry. These items can be pulled into moving parts. Safety glasses and ear protection are recommended.**
- E) MAINTENANCE IS IMPORTANT --- Follow the routine maintenance instructions provided in this manual and your engine manual..**

▲ 6) ENGINE / FUEL WARNINGS

▲ WARNING DANGER ▲

HANDLE FUEL WITH CARE, IT IS HIGHLY FLAMMABLE. FUELING A HOT ENGINE OR NEAR AN IGNITION SOURCE CAN CAUSE FIRE AND RESULT IN SERIOUS PERSONAL INJURY AND / OR PROPERTY DAMAGE.

- A) Do not smoke when handling fuel.**
- B) Do not refuel an engine that is hot or running.**
- C) Do not refuel indoors.**
- D) Do not start or run indoors as poisonous carbon monoxide is emitted.**
- E) Do not operate in un-ventilated area.**
- F) Avoid spilling fuel or oil.**

WARNING - All debris blowers are shipped without oil. When filling with oil, refer to the engine manufacturers operating instructions for proper type and amount.

7) Blower Assembly Instructions

Note: Numbers in brackets refer to exploded view and parts list.

1) Attach front wheel bracket assembly (36) secure with 5/16x3/4 (6) and flat washers (14). Insert axle sleeve (31) into Pneumatic / Flat Free wheel hub, place wheel between brackets and secure with 3/8 x5" cap screw(17) and flange nut(25).

2) Attach lower handle tubes (3) to anti-vibration mounts (2) secure with 3/8 x 1 3/4 hex bolt (23) and flat washers (24).

3) Place lower handle brace plate (16) on lower handle assembly and attach handle (3) using 5/18-18 X 1 3/4" bolt (15), 5/16" washers (14) and 5/16" nylon lock nuts (33).

Note: Handle height and orientation should be observed at this time.

4) Place front discharge baffle (26) into opening in blower housing so hinged bracket is inside square opening. Secure with two 1/4 x 3/4" hex bolts (21), two 1/4-20 flange nuts (28) and two 1/4" flat washers. Make sure baffle opens and closes freely.

5) Secure spring (27) through top hole in front discharge baffle.

6) Place discharge flap (29) on blower output and secure with two 5/16 x 3/4" thumb screws (37).

7) Tighten all fasteners securely.

Fan Removal

(This procedure should only be performed at a qualified dealer)

1. Remove intake guard and ring.

2. Remove 3 bolts securing fan to tapered bushing. Place a 1 1/8" socket or spacer over crank shaft and tap with hammer to drive bushing back toward engine. (8 Hp and above only) This will release fan and allow easy removal. Note: On 6Hp models, the socket or spacer will vary in size according to the crankshaft.

3) When re-installing, replacement of the taper bushing is recommended. Be sure to follow All tightening and torque specifications.

BRAVE

8) Operating Instructions

Refer to Engine Manual for Engine Operation.

Follow directions in the engine manual for operating oil type and quantity.

Leaves, thatch or other debris can be directed into windrows or piles, by simply maneuvering the unit and directing the flow of air accordingly.

Air flow can be directed to the side or front by the two-position deflector. The

9) Maintenance Instructions

1. Keep all nuts, bolts and screws tight.
2. Never store the Blower with fuel in its fuel tank inside a building or in a confined space where fumes may reach an open flame or sparks.
3. Always refer to the instruction manual for important details if the product is to be stored for an extended period.
4. Engine - 4 cycle. (Refer to engine manufacturer's operating instructions for

front discharge position is used to remove debris from along walls, fences, etc., the side discharge position is used to form windrows or piles. The horizontal deflector directs air downward to "chisel" under wet, heavy leaves and litter. The velocity is regulated by the throttle control. Slight changes in deflector will have a big effect on air flow. Experiment until you find the best position for your needs. For best performance, be sure engine recoil starter assembly, the blower intake and outlet areas are clear and free of leaves or other debris.

fuel recommendations and additional information.)

5. Tires - Tubeless. Inflate to air pressure of 30 P.S.I.
6. Labels should be inspected before each use. Replace damaged labels immediately.
7. To prevent accidental starting, remove spark plug wire when servicing engine or equipment.
8. Check oil level regularly.



Warning: The engine exhaust from this product contains chemicals known to the State of California to cause cancer, birth defects or other reproductive harm.

BRAVE

20195 S. Diamond Lake Road, STE 100
Rogers, MN 55374
800-350-8739

Complete Blower Illustration

BRAVE

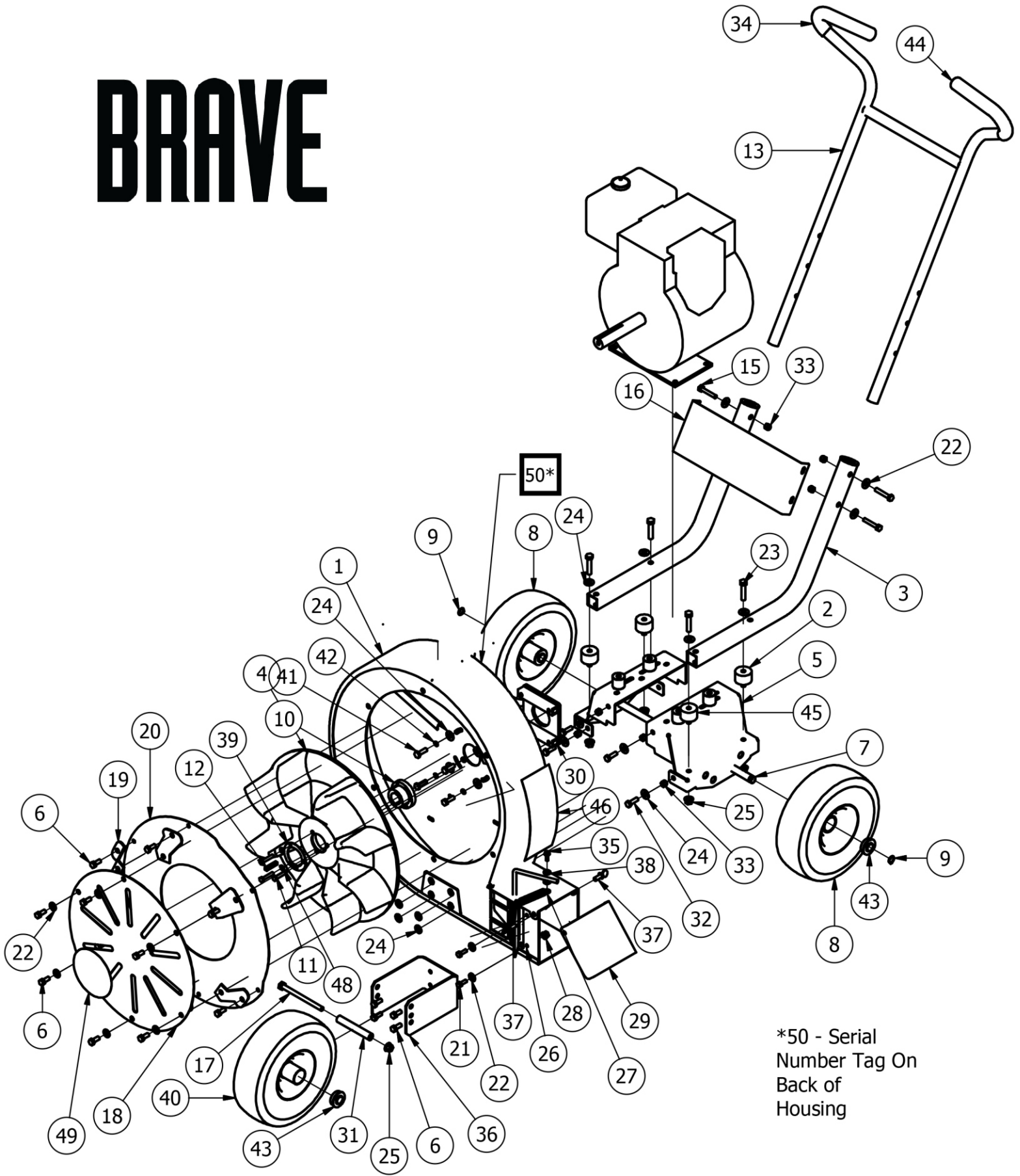

*50 - Serial
Number Tag On
Back of
Housing

Parts List - Blower - Discharge Detail

ITEM	QTY	PART NUMBER	DESCRIPTION
21	2	1100-020	1/4-20 X 3/4" HHCS
22	2	1100-073	1/4" USS FLAT WASHER
26	1	BR1100-022	FRONT DISCHARGE ASSEMBLY
27	1	1100-021	LOOP END EXTENSION SPRING
28	2	1100-019	1/4-20 FLANGE NUT
35	1	1100-014	12-24 x 3/4" DRILL AND TAP SCREW
38	2	11900	1/4" SAE WASHER

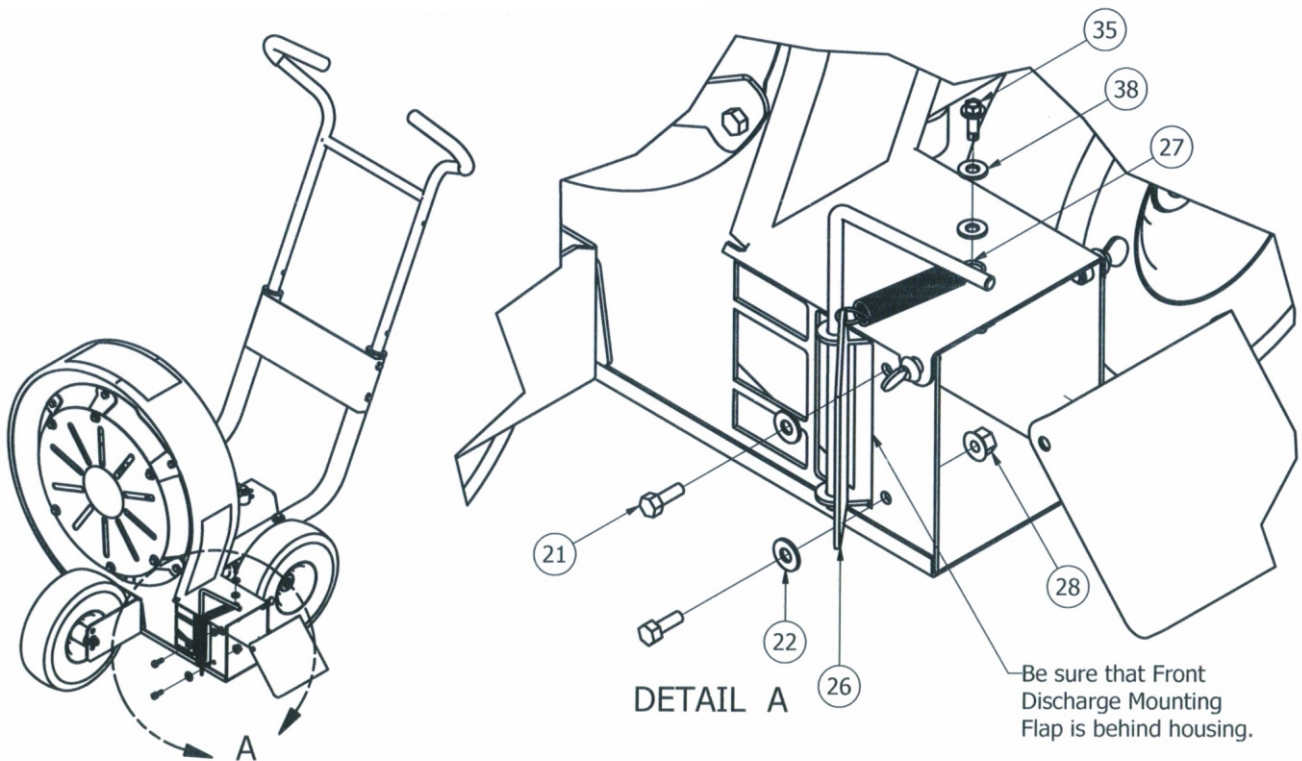

Parts List - Complete Blower

ITEM	QTY	PART NUMBER	DESCRIPTION
1	1	BR1100-062	17" HOUSING ASSEMBLY
2	4	1100-044	RUBBER VIBRATION MOUNT
3	2	BR1100-061	SQUARE TUBE HANDLES
4	1	1100-007	17" IMPELLER
5	2	BR1100-045	MOTOR MOUNT
6	16	1100-075	5/16-18 x 3/4" HHCS
7	1	1100-051	AXLE
8	2	1100-049	REAR TIRE ASSEMBLY
9	2	1100-050	.625" EXTERNAL RETAINING RING
10	1	1100-006	TAPER LOCK BUSHING
11	3	1100-006-SH1	1/4-20 x 1 3/8" HHCS
12	1	1100-012	1/4" KEY STOCK
13	1	BR1100-038	HANDLE WELDMENT
14	12	1100-031	5/16 USS FLAT WASHER
15	4	1100-072	5/16-18 x 1 3/4" HHCS
16	1	BR1100-033	HANDLE BRACE
17	1	1100-026	3/8-16 x 5" HHCS
18	1	BR1100-04A	INTAKE GUARD
19	6	BR1100-003	STAND OFF
20	1	BR1100-04B	INTAKE RING
21	2	1100-020	1/4-20 x 3/4" HHCS
22	12	1100-073	1/4" USS FLAT WASHER
23	4	1100-083	3/8-16 x 1 3/4" HHCS
24	4	1100-043	5/16 USS FLAT WASHER
25	5	1100-047	3/8-16 FLANGE NUT
26	1	BR1100-022	FRONT DISCHARGE ASSEMBLY
27	1	1100-021	LOOP END EXTENSION SPRING
28	2	1100-019	1/4-20 FLANGE NUT
29	1	BR1100-018	DISCHARGE FLAP
30	1	BR1100-058	ENGINE HOUSING SPACER
31	1	1100-056	SPANNER BUSHING
32	4	11815	5/16-18 x 1" HHCS
33	8	11905	5/16-18 NYLON LOCK NUT
34	2	1100-037	FOAM HANDLE GRIP COVER
35	1	1100-014	12-24 x 3/4" DRILL AND TAP SCREW
36	1	BR1100-027	FRONT WHEEL BRACKET
37	2	1100-016	5/16-18 x 3/4" THUMB SCREW
38	2	11900	1/4" SAE WASHER
39	1	BR1100-078	IMPELLER RING
40	1	1100-085	FRONT TIRE ASSEMBLY
41**	4	11916	5/16-24 x 1" HHCS
42	4	11904	5/16 SPLIT LOCK WASHER
43	6	11493	5/8" UNGROUND FLANGED BEARING
44	2	1100-090	HANDLE BAR PLUGS
45**	4	BR1100-057	ENGINE SPACER
46	1	1100-074	WARNING LABEL
47	1	1100-087	LABEL RECTANGULAR
48	3	1100-006-SH2	1/4" LOCK WASHER
49	1	1100-086	LABEL ROUND

BRAVE

Brave Product Registration Form

YOUR INFORMATION

Full Name:

Last First M.I.

Address:

Street Address Apartment/Unit #

City State ZIP Code

Home Phone:

Alternate Phone: _____

Email

PURCHASED FROM

Company:

Address:

Street Address Apartment/Unit #

City State ZIP Code

MODEL INFORMATION

Purchase Date

Application Type

Homeowner

Commercial

Rental

Model *(i.e. BRPT704H)*

Serial # *(i.e. 123456)*

Signature

Register your product online at www.braveproducts.com

This page intentionally left blank



Dear Valued Customer:

The Brave product you just purchased is built with the finest material and craftsmanship. Use this product properly and enjoy the benefits from its high performance. By purchasing a Brave product, you show a desire for quality and durability. Like all mechanical equipment this unit requires a due amount of care. Treat this unit like the high-quality piece of machinery it is. Neglect and improper handling may impair its performance.

Thoroughly read the instructions and understand the operation before using your product. Always contact Brave Product Support at 1-800-350-8739 prior to having any service or warranty work performed, as some services performed by parties other than Brave approved service centers may void this warranty. This limited warranty is in lieu of any other warranty expressed or implied, written or oral and Brave assumes no other responsibility or liability outside that expressed within this limited warranty.

Limited Warranty for Brave Blowers:

BRPB160H BRPB450H

	Consumer Warranty Period	Commercial Warranty Period
Weldments	2 years from date of purchase by user	2 year from date of purchase by user
Wear Parts	In addition to the normal warranty, Brave shall warrant any normal wear items from defects in material or workmanship for a period of 30 days from the date of purchase by user. Normal wear items include, but are not limited to fans, bearings, zerks, impeller, throttle control assembly, springs, seals, tires, wheels.	
Engines	The engine warranty is covered under the terms and conditions as outlined by the engine manufactures warranty contained herein and is the sole responsibility of the engine manufacturer. Normal engine maintenance such as spark plugs, oil changes, air filters, adjustments, fuel system cleaning and obstruction due to build up is not covered by this Brave limited warranty.	

“**Consumer use**” means personal residential household use by a consumer. “**Commercial use**” means all other uses, including, but not limited to, use for commercial, income producing or rental purposes or when purchased by a business.

This limited warranty applies to the original purchaser of the equipment (verification of purchase, in the form of a receipt, is the responsibility of the buyer), is non-transferable, and covers parts and labor. Parts will be replaced or repaired at no charge, except when the equipment has failed due to lack of proper maintenance. If a part is no longer available, the part may be replaced with a similar part of equal function. Any misuse, abuse, alteration or improper installation or operations will void warranty. Determining whether a part is to be replaced or repaired is the sole decision of Brave. Brave will not provide for replacement of complete products due to defective parts. Any costs incurred due to replacement or repair of items outside of a Brave approved facility is the responsibility of the buyer and not covered under warranty. Transportation costs to and from service center and/or service calls are the responsibility of the customer.

This limited warranty specifically excludes the following: failure of parts due to damage caused by accident, fire, flood, windstorm, acts of God, applications not approved by Brave in writing, corrosion caused by chemicals, use of replacement parts which do not conform to manufacturer’s specifications, damage related to rodent and/or insect infestation and damage caused by vandalism. Additional exclusions: loss of running time, inconvenience, loss of income, or loss of use, including any implied warranty of merchantability of fitness for a specific use. Also, outdoor power equipment needs periodic parts and service to perform well, and this limited warranty does not cover instances when normal use has exhausted the life of a component or the engine.

This limited warranty does not cover any personal injury or damage to surrounding property caused by failure of any part, misuse or inability to use the product. Alteration of the product, including safety features, shall void this limited warranty.

Repair or replacement of parts does not extend the warranty period. This limited warranty gives you specific legal rights. You may also have other rights that vary by state. Please have model number, item number and serial number on hand prior to making a warranty claim or inquiry.

BRAVE

**20195 S. Diamond Lake Road, STE 100
Rogers, MN 55374
800-350-8739**